

On a Rational Method of Analysis and Design of Tunnel Supports Based on the Finite Element Technique

सिपकनु माता मली रता नः



W.G. Louhenapessy and G.N. Pande
Department of Civil Engineering,
University of Wales,
Swansea, Singleton Park,
Swansea, SA2 8PP, UK
Tel: 01792 295517
Fax: 01792 295676/295517
Email: g.n.pande@swansea.ac.uk

ABSTRACT

The Q-system, also called the Norwegian Geotechnical Institute (NGI) classification system (Barton et al., 1974), plays an important role in the design of supports in tunnels excavated in rock and is frequently used in many parts of the world. One of the major shortcomings of the NGI classification system is that it does not take into account the orientation of rock joints with respect to the exposed surface of the tunnel excavation. This paper propose a rational methodology in which the NGI classification system is enhanced by taking into consideration the influence of the orientation of joint set(s). Using the finite element method and the multilaminate model for jointed rock masses (Zienkiewicz and Pande, 1977), a set of design charts and tables useful to the practising engineers for circular tunnels are presented. A numerical example is given to illustrate their use.

1.0 INTRODUCTION

Construction of tunnels, by and large, is an art. Tunnels have been constructed by the engineers for many centuries. Many kilometers of tunnels are still being constructed every year throughout the world specially in developing countries. A large percentage of these are constructed in rock which is not competent and therefore tunnel supports in the form of rock bolts, shotcrete lining, steel arches etc. have to be provided. The supporting system contributes to a substantial cost of tunnelling operation and has to be carefully designed. It is, however, not an easy task since analysis of tunnel support is a complex problem of rock-structure interaction which cannot be solved by simple engineering analysis techniques. Advanced numerical methods have been frequently adopted but they are not suitable for routine analysis specially when unforeseen conditions are encountered on site during construction. Although engineers and geologists have accumulated past experience in the analysis and design of tunnel supports, this experience is not readily transferrable from one location to the other due to a large number of factors that influence the pressure which is applied on the supporting system and the inherent variability of ground conditions. Consequently, several empirical methodologies based on the past experience which define the quality

of the rock according to a certain classification system have been proposed. Rock mass classification systems, such as the NGI classification system (Barton et al., 1974); RMR system (Bieniawski, 1974); RM_i system (Palmstrom; 1995; Palmstrom, 1996); Modified NGI system (Bawden, 1993; Germain and Milne, 1991; Milne et al., 1991) and others (Bieniawski, 1990) are efforts to assess rock mass properties and express the rock condition as a single number. They cover a wide range of condition encountered in the field (Hoek, 1982; Serafim and Pereira, 1983; Bieniawski, 1984; Bawden, 1993; Sofoco, 1994; Hoek et al., 1995). Unfortunately many of the input parameters in these systems are very difficult to measure (Milne et al., 1991).

This paper identifies the influence of joint orientation and in-situ stresses in the rock mass on the pressure on tunnel supports in circular tunnels. A multilaminate model is adopted for the analysis of the elastic response of the rock mass on the excavation of the tunnel. A support pressure is computed to prevent (a) the failure of joint sets in either shear or tension (b) the failure of intact rock. Only the case of passive rock bolts as the support system is considered here although the methodology can be applied to shotcrete lining on its own or in combination with rock bolts. It is shown that, as expected, the use of NGI's classification system leads to an over-conservative design in some cases whilst leading to unsafe design in others.

Section 2.0 discusses the factors influencing the stability and failure of rock masses. Section 3.0 deals with brief details of the NGI's rock mass classification system and the method of calculating the requirement of tunnel supports on the basis of tunnelling quality index (Q). Section 4.0 deals with derivation of a general framework for constitutive model for jointed rock masses. The proposed methodology of calculating tunnel support pressure is described in section 5.0. Rose diagrams for tunnel support pressure and design aids are presented in section 6.0 along with a comparison of results with the NGI classification for two specific cases.

2.0 FACTORS INFLUENCING INSTABILITY IN ROCK TUNNELS

Collapse of the tunnel roof, sides or face takes place when the stresses which are imposed on the rock mass due to excavation exceed its strength. Thus, the factors which influence the collapse of a tunnel are in turn the factors which influence (a) strength of the rock mass and (b) the factors which vary the stresses imposed during excavation. In the following we examine these factors to develop a deeper understanding of the requirements of tunnel support analysis.

2.1 The factors affecting the strength of rock masses

The strength of jointed rock masses is affected by the presence of joints, mechanical properties of joints, their orientation and spacing and also the strength of the intact rock. There are a large number of factors on macroscopic and microscopic scale which affect the shear strength of joints and it is not proposed to discuss them here. Generally, the orientation of joints and their strength are the most important parameters for the stability of tunnels in jointed rock masses. An accurate constitutive model for

the jointed rock mass in the framework of a multilaminate model is required as proposed in (Pande, Beer and Williams, 1990). Assuming applicability of Terzaghi's 'effective stress' principle the strength is also governed by the presence of water since it is the effective stress that controls failure and not the total stress.

2.2 Factors affecting stresses imposed on excavation

The state of stress in the rock mass prior to excavation profoundly affects the stresses to which the rock mass in the periphery of the tunnel is subjected to. This is generally described by in-situ stress ratio K_0 being defined as the ratio of horizontal effective stress to the vertical effective stress at a point. It should, however, be noted that the directions of in-situ stress may not always coincide with the orientation of tunnel axis. In addition to the state of in-situ stress, the depth, the size and geometry of the tunnel and the stages of excavation also affect the loading imposed by excavation on the rock mass

3.0 THE NGI ROCK CLASSIFICATION SYSTEM

Barton, Lien and Lunde (Barton et al., 1974) have studied the problem of rock mass classification for tunnel excavation and supports. Based on 200 underground case histories a Tunnelling Quality Index - Q- has been proposed based on 6 parameters. The value of Q is in the range of $0.001 < Q < 1000$ (Table 1) and is defined by,

$$Q = \frac{RQD}{J_n} \cdot \frac{J_r}{J_a} \cdot \frac{J_w}{SRF} \quad (1)$$

where RQD is the Rock Quality Designaion, J_n is the joint set number, J_r is the joint roughness number, J_a is the joint alteration number, J_w is the joint water reduction factor and SRF is the stress reduction factor.

The relationship between Q and the permanent support pressure P_{roof} is calculated from the following equation (Barton et al., 1974),

$$P_{roof} = \frac{2}{3} J_n^{\frac{1}{2}} J_r^{-1} Q^{-\frac{1}{3}} \quad (2)$$

It is fruitful to look at equation 1 closely. Though statistically obtained this equation has a number of factors affecting strength of the rock mass and the loading imposed due to excavation, as disussed in section 2.0 above. The parameters RQD, J_r , J_a , J_n are indirectly related to the strength of the rock mass, J_w is meant to account for strength reduction due to the cosiderations of effective stress and SRF is deemed to account for in-situ stresses in some indirect way. The value of Q varies six orders of magnitude and most of the parameters vary over a wide range. In practice the choice of the parameters is extremely subjective and this ultimately leads to an arbitrary value of support pressure. In spite of these drawbacks, the above precedure of

calculating support pressure has become popular with engineers and geologists in recent years obviously due to its simplicity. However, it is not rational as its approach is akin to that of a medic who bases his treatment solely on case histories and past

Table 1: Q Classification System (Barton, Lien and Lunde, 1974)

Tunnelling Quality Index	Q
0.001 - 0.01	Exceptionally Poor
0.01 - 0.1	Extremely Poor
0.1 - 1	Very Poor
1 - 4	Poor
4 - 10	Fair
10 - 40	Good
40 - 100	Very Good
100 - 400	Extremely Good
400 - 1000	Exceptionally Good

experience. The problem of computation of tunnel support pressure is a fully tractable with the use of present generation of portable computers and should be solved by engineers who are entrusted with the task of designing and constructing tunnels, mines and underground openings.

4.0 A GENERAL FRAMEWORK FOR CONSTITUTIVE MODELS FOR JOINTED ROCK MASSES

Multilaminar framework for developing a constitutive model for jointed rock masses has been discussed in detail in various publications of Pande and his co-workers (Naylor and Pande, 1981; Pande and Xiong, 1982; Pande and Gerrard, 1983; Gerrard and Pande, 1985; Sharma and Pande, 1988; Chen and Pande, 1994). The model has been popular with consulting engineers throughout Europe and software based on this model is marketed by many companies, e.g. TDV GmbH (1994) and VIPS Ltd. (1996). Here, a brief outline of the framework is given for the sake of continuity and completeness. For detailed information one should refer to Zienkiewicz and Pande (1977) and Pande (1993).

4.1 Elasticity matrix of jointed rock masses.

A representative volume of a jointed rock mass cannot be tested in laboratory to derive its constitutive parameters. The elastic constants of a rock mass can, in principle, be determined from large scale in-situ experiments or geophysical experiments. However, these experiments are expensive and time consuming. An alternative approach is to derive the elasticity matrix of the rock mass from the constitutive properties of its constituents. The philosophy here is to treat jointed rock mass from the constitutive properties of its constituents. The philosophy here is to treat jointed rock mass as a composite material with intact rock joints as its

constituents. Based on laboratory testing of intact material and the rock joints and given the fabric of joint sets, it is possible to determine the constitutive matrix (D) of the jointed rock mass following a standard mathematical procedure. Here we shall restrict ourselves to the most common geometry of continuous rock joints and shall make the following assumptions:

1. Joints are continuous, unfilled and parallel with regular spacing which is small compared to the overall dimension of the problem.
2. The intact rock, as well as, joints behave in an elastic-plastic manner.

Any valid yield/failure criterion, flow rule and hardening/softening rule can be used. However, in practice it is difficult to obtain corresponding parameters and the assumptions of ideal plasticity are generally made with Mohr-Coulomb yield criterion being commonly used for intact rocks as well as rock joints.

Full details of the derivation of the tangential elasto-plastic matrix are given elsewhere (Pande, Beer and Williams, 1990; Pande, 1993). Here we restrict our levels to the derivation of the elasticity matrix of the jointed rock mass since this is all that is required for following the proposed methodology of computation of support pressure in tunnels.

We first define unit joint stiffness in the standard way. Consider a direct test σ_n a rock joint specimen in the laboratory. At first, normal stress, σ_n , is applied and the specimen shortens as the asperities in the joint deform (δ_n). The joint normal deformation, (δ_n), can be plotted against the applied normal stress Figure 1(a). It is noted that σ_n is compressive only.

Now, consider shear stress, τ_s , being applied horizontally (x direction) producing joint tangential deformation, δ_s , as shows Figure 1(b). This ratio of increment of stress to deformation at the initial stage gives the elastic stiffness of the rock joint-normal and tangential. No cross coupling terms are assumed and dilation of the joint is introduced through flow rule in the plastic region only.

The local compliance matrix, C_l^j , of a set of rock joints is represented by

$$C_l^j = f \begin{bmatrix} D_n & 0 & 0 \\ 0 & D_s & 0 \\ 0 & 0 & D_s \end{bmatrix}^{-1} \quad (3)$$

where f is the frequency of joints (number of joint/meter). The local compliance is transformed to a global system using the transformation matrix, T , as

$$C_g^j = TC_l^j T^T \quad (4)$$

The cumulative compliance for "n" joint sets, C_g^s is

$$C_g^s = \sum_{i=1}^n TC_i^j T^T \quad (5)$$

and the compliance of the rock mass becomes,

$$C = \left(\sum_{i=1}^n TC_i^j T^T \right) + [D_e^i]^{-1} \quad (6)$$

where D_e^i is the conventional elasticity matrix of the intact rock (Lubliner, 1990). Therefore, the elasticity matrix of rock mass, D_e^m , is reduced to

$$D_e^m = \left[\sum_{i=1}^n TC_i^j T^T + [D_e^i]^{-1} \right]^{-1} \quad (7)$$

In simple terms, assuming intact rock to be isotropic and elastic, given the following parameters:

1. elastic modulus and Poisson's ratio of intact rock
 2. elastic normal and tangential stiffness of joints
 3. the number, orientation and spacing of joints in each set, the elasticity matrix of the jointed rock mass can be explicitly computed.
- 5 Methodology of computation of pressure on tunnel supports

The methodology proposed here for the computation of pressure on tunnel supports is based on a practical approach which is commonly used in many areas of engineering design. Since the behaviour of a jointed rock mass is highly nonlinear, considerable computational effort is needed for solving the complex rock-structure interaction problem. This is not practical as specialist expertise in numerical modelling is needed. An alternative is to apply the so called 'stress path method' in which an estimate is made of the stress path experienced at a few typical points in the structure. The stability of these points in the rock mass is considered based on the adopted failure criterion and the support pressure is computed, if required, in such a way that the rock mass is prevented from collapse.

For example, consider a point such as A on the roof of the tunnel (see Figure 2) excavated at a certain depth in a jointed rock mass having "n" sets of joints. Before excavation this point experiences geostatic stresses. The stresses at this point after excavation which may be in stages can be computed assuming jointed rock mass as an anisotropic multilaminate material having the elasticity matrix given by Equation 7. Here, finite element analysis has to be used but since it is only an elastic analysis it is within the capability of a practising engineer as standard programs are readily available, e.g. MISES3 (1994) and VISAGE(1996). The deviation of stress from the geostatic condition is readily obtained and gives the stress path (see Figure 2) to which a rock mass will be subjected to at point A. This stress path at a point is

imposed on rock mass and computation made to judge if failure in any of the following modes is possible:

1. Failure of intact rock: the strength parameters of the intact rock are examined and the failure function is checked.
2. Failure of joint sets: the strength parameters are examined and failure in shear or tension is checked.

If failure is observed in any of the modes, a pressure (p) normal to the periphery of tunnel is computed which would prevent the failure of the rock mass at that point. It may be noted that in some cases, application of a normal pressure through passive bolts may not be able to prevent failure or the spacing of rock bolts may be too small for adoption in practice. In such case a combination of shotcrete lining and rock bolts at an inclination may be required.

The above procedure is repeated at a number of points on the periphery of the tunnel and simple engineering calculations are made to determine the spacing of passive rock bolts of a given diameter.

6.0 NUMERICAL EXAMPLES

In this section, analysis of a 12.8 m diameter circular tunnel excavated at various depths in the jointed rock having one or two sets of joints is presented for the illustration of the methodology of computing support pressures. Here, a two-dimensional idealization as adopted through extension of the three-dimensional situation is straight forward. Figure 3 depicts the geometry of the problem. The notations for describing the fabric of the rock joints is shown in the inset. The material parameters assumed for illustration are shown in Tables 2 and 3.

As seen from Table 3, depth to diameter ratio varies from 6.25 for the shallow tunnel (sd0) to 125 for the very deep tunnel (vd4). Support pressure has been computed for the rock mass having one set of joints at various orientations as well as, for two sets of joints. The results for only one set of joints are presented here, due to lack of space. Figure 3 shows the tunnel geometry.

Results for multiple sets will be presented elsewhere (Louhenapessy and Pande, 1997). For the calculation of stress paths, elastic finite element analysis is undertaken. Figure 4 shows the typical finite element mesh used for the analysis which consists of 736 nodes and 224 eight-noded *isoparametric* elements. In view of the approximate nature of the method of calculation, the fineness of the mesh is not crucial and it is assumed that the mesh shown in Figure 4 gives accurate stress paths for practical purposes.

Eight points have been chosen on the circumference of the tunnel for studying the requirement of support pressure. Three cases of in-situ stress corresponding to $K_0 = 0.333, 1.00$ and 2.00 have been studied. It is noted that cohesion for joints is adopted as zero and the friction angle is varied between 10° to 50° .

6.1 Rose diagrams of support pressure

Rose diagrams are useful tools for presenting results of parametric studies of tunnel support pressure analysis. Here the support pressure required at a point on the periphery of the tunnel is plotted on a radial line, the length of which represents the support pressure. Such diagrams are shown in figures 5 to 10. The support pressure has been normalised with reference to geostatic stress at the centre of the tunnel before excavation. Figures 5(a)-(d); Figures 6 (a)-(d) and Figures 7(a)-(d) are for **sd0** tunnel for the case when the joints are inclined at $\theta = 0^\circ, 45^\circ, 60^\circ$ and 90° and $K_o = 0.333, 1.00$ and 2.00 respectively. Figures 8 to 10 are for **vd4** tunnel for the same cases as Figure 5-7.

From these rose diagrams, support pressure can be obtained based on the depth of tunnel, joint friction angle ϕ , in situ stress ratio, K_o , and orientation of the joints, θ .

Table 2 : Rock properties for tunnel in jointed rock mass

Intact rock	$E = 7 \times 10^7$ kPa Rocktype: SANDSTONE $\nu = 0.3$ $C_i = 28870$ kPa $\phi_i = 30^\circ$ $\gamma = 24.5$ kN/m ³
Joint rock	$C_n = 1 \times 10^{-7}$ kPa ⁻¹ $C_s = 2 \times 10^{-7}$ kPa ⁻¹ Cohesion = 0 $\phi = 10^\circ, 20^\circ, 30^\circ, 40^\circ$ and 50° spacing = 1m
K_o	0.333, 1.0 and 2.0

Table 3 : Name (Type), Depth and "Depth/Diameter" of the Tunnel

Type	depth h(m)	Depth/Diameter
sd0	80	6.25
vd0	160	12.25
vd2	640	50.0
vd4	1600	125

The requirement of support pressure vary from point to point on the periphery of the tunnel. Obviously, engineering judgment has to be used and provision should be made for maximum required support pressure in any section.

It should be noted that in most cases the failure takes place due to sliding on joints but there are also situations in which joint open or intact rock fails, the latter case arising at very high depth/diameter ratio.

6.2 Comparison with the NGI classification system

Here we examine two specific cases of the support pressure requirements and compare them with those obtained from the NGI classification system. The first case is that of shallow tunnel, "sd0" (CASE I), with K_0 being 0.333, 1.0 and 2.0, while the second case is that of very deep tunnel, "vd4", (CASE II). The tunnels are in sandstone with one set of joint and intact rock having compressive strength (σ_c) of 100 MPa.

The following data have been assumed for comparison,

* Assume, RQD = 72%, based on judgments and experiences of the various references (Deere, 1968; McLean and Gribble, 1985; Oberti et al., 1986; ENG, 1993; ENG, 1993; Sofoco, 1994; Waltham, 1994; Palmstrom, 1995; Natau et al., 1995; Hoek et al., 1995; Sheorey, 1997),

* $J_n = 2$ (one joint set),

* $J_r = 1.5$ (planar rough or undulating slickenside) (Hoek et al., 1995),

* $J_a = 1.0$ (unaltered joint walls, surface staining only),

* $J_w = 1.0$ (no water/dry),

* for *sd0* tunnel:

$$\frac{\sigma_c}{\sigma_1} \approx 91.5 \text{ (medium stress, SRF = 1.0)}$$

where $\sigma_c = 100$ MPa and $\sigma_1 \approx 1.09$ MPa

* for *vd4* tunnel:

$$\frac{\sigma_c}{\sigma_1} \approx 3.75 \text{ (high stress, SRF = 7.0)}$$

where $\sigma_c = 100$ MPa and $\sigma_1 \approx 26.67$ MPa.

σ_1 is the maximum principal stress obtained from the elastic finite element analysis using multilaminate model.

Based on the above parameters :

for *sd0* tunnel, $Q = 54.00$ and $P_{roof} = 16.6$ kPa and,

for *vd4* tunnel, $Q = 7.71$ and $P_{roof} = 31.8$ kPa.

Assuming, 25 mm (diameter) steel bolts, their spacing is obtained as 2970 mm c/c. and 2150 mm c/c respectively.

Table 4 and 5 show the comparison of spacing of rock bolts for cases I and II respectively computed on the basis of the proposed methodology. It is obvious that whilst NGI system gives a single spacing for each case, the spacing based on the theory of this paper varies depending primarily on the orientation of joints. NGI system does not always give a safe spacing.

In general, rose diagram gives more extensive information i.e. the zone and extent of area to be rock bolted is indicated. Moreover, they provide a more rational and practical solution as compared to that proposed by any classification system.

It may be noted that rock bolt normal to the periphery of the tunnel may not be effective in certain situation i.e. the orientation of the joints may be such that no amount of normal pressure would prevent joint failure. Here alternative methods of grouting, shotcrete lining etc. have to be explored.

Table 4 : Roof Bolt Spacing (Diameter = 25 mm)

CIRCULAR TUNNEL "sdo"; Depth = 80 m							
Orientation θ	insitu stress ratio K_o	NGI (mm)	Wi (mm)				
			joint friction angle, ϕ				
			10°	20°	30°	40°	50°
0°	0.333	2970	2150	2150	2150	2150	2150
	1.0	2970	No*	No*	No*	No*	No*
	2.0	2970	No*	No*	No*	No*	No*
45°	0.333	2970	970	960	930	850	No*
	1.0	2970	220	220	220	210	No*
	2.0	2970	X**	X**	X**	X**	No*
60°	0.333	2970	620	800	No*	No*	No*
	1.0	2970	230	300	No*	No*	No*
	2.0	2970	X**	200	No*	No*	No*
90°	0.333	2970	No*	No*	No*	No*	No*
	1.0	2970	No*	No*	No*	No*	No*
	2.0	2970	No*	No*	No*	No*	No*

* NO = no support required
**X = spacing too small, [not practical]

Table 5 : Roof Bolt Spacing (Diameter = 25 mm)

CIRCULAR TUNNEL "vdo"; Depth = 1600 m							
Orientation θ	insitu stress ratio K_0	NGI (mm)	W_i (mm)				
			joint friction angle, ϕ				
			10°	20°	30°	40°	50°
0°	0.333	2150	440	440	440	440	440
	1.0	2150	280	280	280	280	280
	2.0	2150	X**	X**	X**	X**	X**
45°	0.333	2150	X**	X**	X**	X**	X**
	1.0	2150	X**	X**	X**	X**	X**
	2.0	2150	X**	X**	X**	X**	X**
60°	0.333	2150	X**	X**	NO*	NO*	NO*
	1.0	2150	X**	X**	NO*	NO*	NO*
	2.0	2150	X**	X**	X**	X**	X**
90°	0.333	2150	NO*	NO*	NO*	NO*	NO*
	1.0	2150	NO*	NO*	NO*	NO*	NO*
	2.0	2150	X**	X**	X**	X**	X**

* NO = no support required
**X = spacing too small, [not practical]

7.0 CONCLUSION

Analysis and design of tunnel support system is a complex problem of rock structure analysis. In this paper a rational but practical method of computing support pressure has been suggested. It is based on the 'stress path' method of analysis. The stress path at a number of point on the periphery of the tunnel is computed using an elastic finite element method.

A multilaminate theory is used to compute the support pressure which would prevent the collapse of the rock mass. The methodology is explained by a set of rose diagram. It is proposed that the engineers should develop similar diagram for the tunnel based on actual laboratory/ field data. These design charts can be readily read for any situation during construction.

The methods of excavation of support pressure based on a classification system lack rationale and should be used with caution.

REFERENCES

1994. *MISES3- User's Manual Rev. 10.1*. TDV GmbH, Graz, Austria.
1996. *The Visage System-User's Guide, version 6.0* VIPS Ltd., Kingston, Surrey, England.
- Barton, N., Lien, R., & Lunde, J. (1974). "Engineering classification of rock masses for the design of tunnel support", *Rock Mech.*, 6, pp. 189-236.
- Bawden, W.F. (1993). "The Use of Rock Mechanics Principles in Canadian Underground Hard Rock Mine Design", Chap. 11, pages 247-290 of : Hudson, J.A., Brown, E.T., Fairhurst, C., & Hoek, E. (eds), *Comprehensive Rock Engineering: Principles, Practice and Projects*, vol. 5. Pergamon Press.
- Bieniawski, Z.T. (1974). "Geomechanics classification of rock masses and its application in tunneling", *Proc. 3rd Int. Congress on Rock Mech.*, vol. IIA. ISRM, Denver, pp. 27-32.
- Bieniawski, Z.T. (1984). "Rock Mechanics Design in Mining and Tunnelling", 1 edn. Rotterdam: A.A. Balkema. 272 p.
- Bieniawski, Z.T. (1990). "Engineering rock mass classification", 1 edn. Chichester: Wiley.
- Chen, S.H., & Pande, G.N. (1994). "Rheological model and FEA of jointed rock masses reinforced by passive, fully-grouted bolts", *Int. J. Rock Mech. Min. Sci. & Geomech. Abstr.* **31**(3), again another REOROC application, pp. 273-277.
- Deere, D.U. (1968). "Geological consideration", Pages 1-20 of: Stagg, K.G., & Zienkiewicz, O.C. (eds), *Rock Mechanics in Engineering Practice*, London: John Wiley & Sons.
- ENG. (1992). "PPLI-B3 Project [WMI Hazardous Waste Center]: Site Investigation Report", PT Environment Nusa Geotechnica & Dames and Moore.
- ENG. (1993). "Waste Management International Hazardous Waste Centre: Site Investigation Report", PT Environment Nusa Geotechnica & Dames and Moore.
- Fleming, W.G.K., Grant, W.G., Mellors, T.W., Skipp, B.O. & Worsfold, R.A. (eds). (1993), *Special Issue: The Channel Tunnel, part 1: TUNNELS. Special Issue: Part 1*. London: Institution of Civil Engineers, for ICE.
- Germain, P., & Milne, D. (1991). "Field observation for the standardization of the NGI classification system", In: *Proc. of the 9th Canadian Tunneling Conf.*, vol.1.

- Germain, P., & Pande, G.N. (1985). "Numerical modelling of reinforced jointed rock masses", Part I: Theory, Computers and Geotechnics. 2(4), pp. 293-319.
- Heim, A. (1905). Vrtl. Jahrschrift der Naturforschenden Gessellschaft in Zurich. In: Tunnelbau und Gebirgsdruck. Zurich : Fasi & Beer.
- Hoek, E., Kaiser. P.K., & Bawden, W.F. (1995). Support of Underground Excavations in Hard Rock. 1 edn. Rotterdam: A.A. Balkema.
- Hoek, E. and Brown E.T. (1982). "Underground Excavation in Rock. 1 edn. London, UK: Institution of Mining and Metallurgy", 527p. - Revised first edition.
- John, M. (1976). "Geotechnical measurements in the Arlberg Tunnel and their consequences on construction", [in German]. Rock Mech. Supplement, pp. 157-177.
- Louhenapessy, W, & Pande, G.N. (1997). A Rational Finite Element Analysis (FEA) Based Procedure for The Analysis of Pressure on Tunnel Supports. Internal Report no: CR/964/97, Department of Civil Engineering: Univ. of Wales, Swansea.
- Lovering, T.S. (1928). "Geology of the Moffat Tunnel. Pages 337-346 of: Transactions AIME, vol. 76-22. AIME.
- Lubliner, J. (1990). Plasticity Theory. 1 edn. New York: Macmillan Publishing Company.
- McLean, A.C., & Gribble, C.D. (1985). Geology for Civil Engineers. 2 edn. London UK: George Allen & Unwin. 314p. - Revised by C.D. Gribbel.
- Miline, D., Germin, P., Grant, D., & Noble, P. (1991). "Systematic rock mass characterization for underground mine design", Proc. -7th Int. Congress on Rock Mechanics, Vol. 1. Aachen: A.A. Balkema, for ISRM., pp. 293-298.
- Natau, O, Buhler, M, Keller, S & Mutschler, T. (1995). "Large scale triaxial test in combination with a FEM analysis for the determination of the properties of a transversal isotropic rock mass", Fuji, T(ed), 3th Inteernational Congress on Rock Mechanics - Frontiers of Rock Mechanics Towards The 21st century, vol. 2. ISRM, Tokyo, Japan., pp. 635-643 .
- Naylor, D.J. & Pande, G.N. (1981). Finite Elements in Geotechnical Engineering Swansea: Pineridge Press. 245p.
- Oberti, G, Bavestrello, F, Rossi, P, & Flamigni, F. (1986). "Rock Mechanics Investigation, Design and Construction of the Ridracoli Dam", Rock Mechanics & Rock Engineering, 19, pp. 113-142.

- Palmstrom, A. (1995). "RMI- a system for characterizing rock mass strength for use in rock engineering", *J. of Rock Mech. & Tunnelling Tech.*, 1(2), 69-108.
- Palmstrom, A. (1996). "Rock Mass Index (RMI) applied in rock mechanics and rock engineering, *J. of Rock Mech. & Tunnelling Tech.*, 2(1), 1-40.
- Pande, G.N. (1993). Constitutive models for jointed rock masses. Chap. 17, pages 427-441 of: Hudson J.A., Brown, E.T., Fairhurst, C., & Hoek, E. (eds), *Comprehensive Rock Engineering: Principles, Practice and Projects*, vol. 1, Pergamon Press.
- Pande, G.N. & Gerrard C.M. (1983). "The behaviour of reinforced jointed rock masses under various simple loading states", *Proc. 5th Congr. Int. Soc. for Rock Mech.*, vol. F. Melbourne: A.A. Balkema and Australian Geomechanics Society, for ISRM., pp. 217-223 .
- Pande, G.N., Beer & Williams, J.R. (1990). *Numerical Methods in Rock Mechanics*, Chichester: John Wiley. 327 p.
- Pande, G.N. & Xiong, W. (1982). "An improved multi-laminated model of jointed rock masses", Dungar, Pande, & Studer (eds), *International Symp. on Numerical Models in Geomechanics*, A.A. Balkema., pp.218-226.
- Serafim, J.L. & Pereira, J.P. (1983). "Consideration of the Geomechanics Classification of Bieniawski", In: *Proc. Int. Symp. on Engng Geol. and Underground Constr.* Lisbon: LNEC.
- Sharma, K.G. & Pande, G.N. (1988). "Stability of rock masses reinforced by passive fully grouted rock bolts", *Int. J. Rock Mech. Min. Sci. & Geomech. Abstr.*, 25(5), pp. 273-285.
- Sheorey, P.R. (1997). *Empirical Rock Failure Criteria*. 1 edn. Rotterdam: A.A. Balkema.
- Sofoco, (1994). Report on rock coring work at the proposed Transbarelang Bridge No. 1, Site Batam-Tonton. major contributor: Mr. B. Kumara.
- Waltham, A.C. (1994). *Foundations of Engineering Geology*. 1 edn. London: Blackie Academic & Professional.
- Zienkiewicz, O.C. & Pande, G.N. (1977). "Time dependent multi-laminate model of rocks a numerical study of deformation and failure of rock masses", *Int. J. Numerical and Analytical Meth. in Geomech.*, 1(1), pp. 219-247.

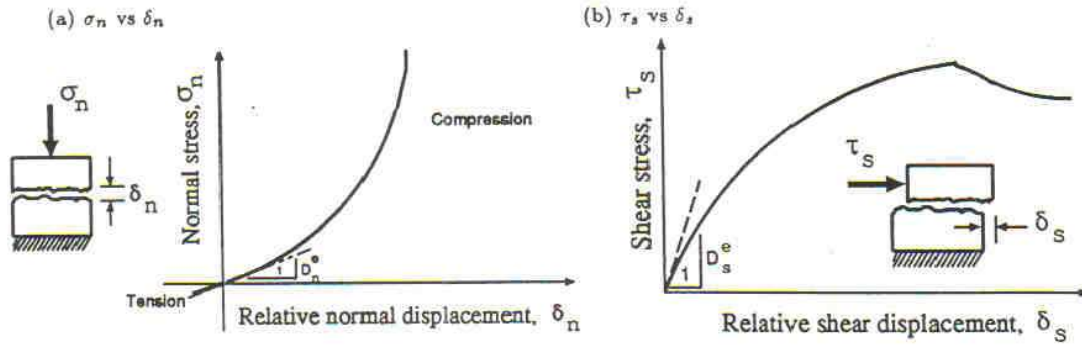

Figure 1 : Typical stress-relative displacement curve

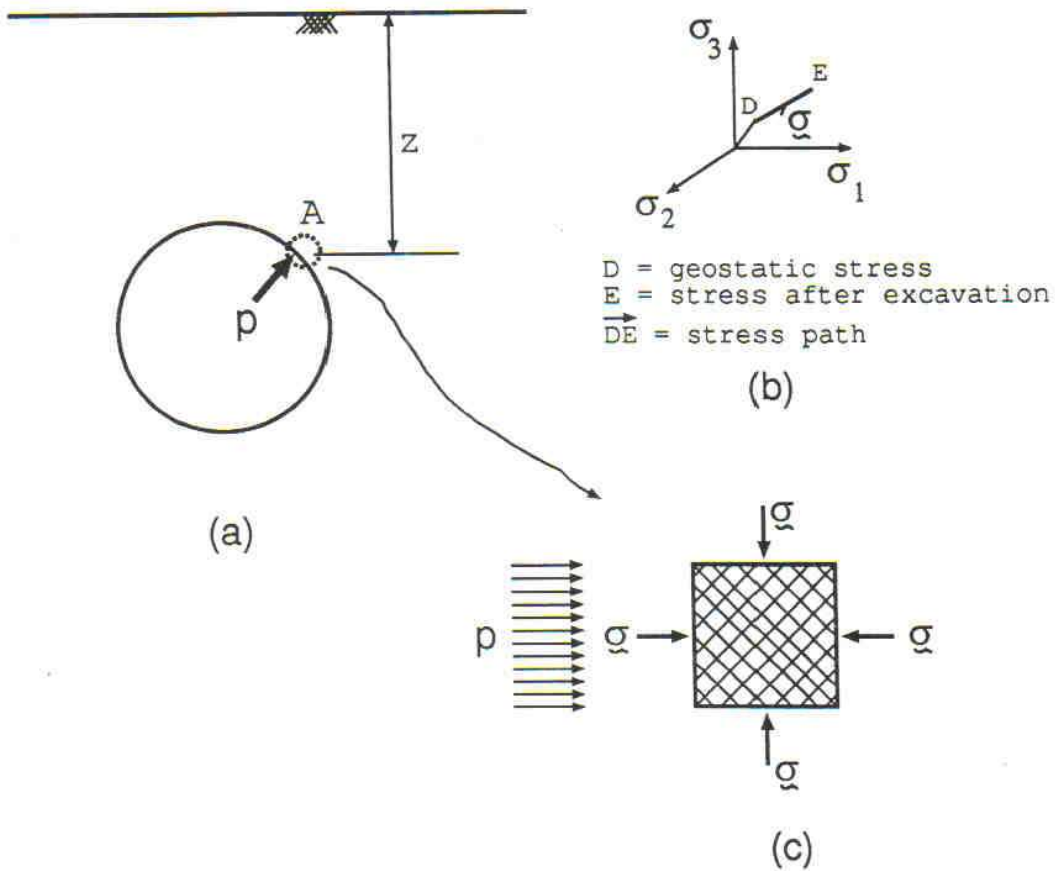

Figure 2 : Pressure applied normal to the tunnel periphery at point A to prevent failure of joint sets. (a) geometry of the problem, (b) stress path experienced by point A in principal stress space, (c) application of normal support pressure to prevent failure under the stress path experienced by point A.

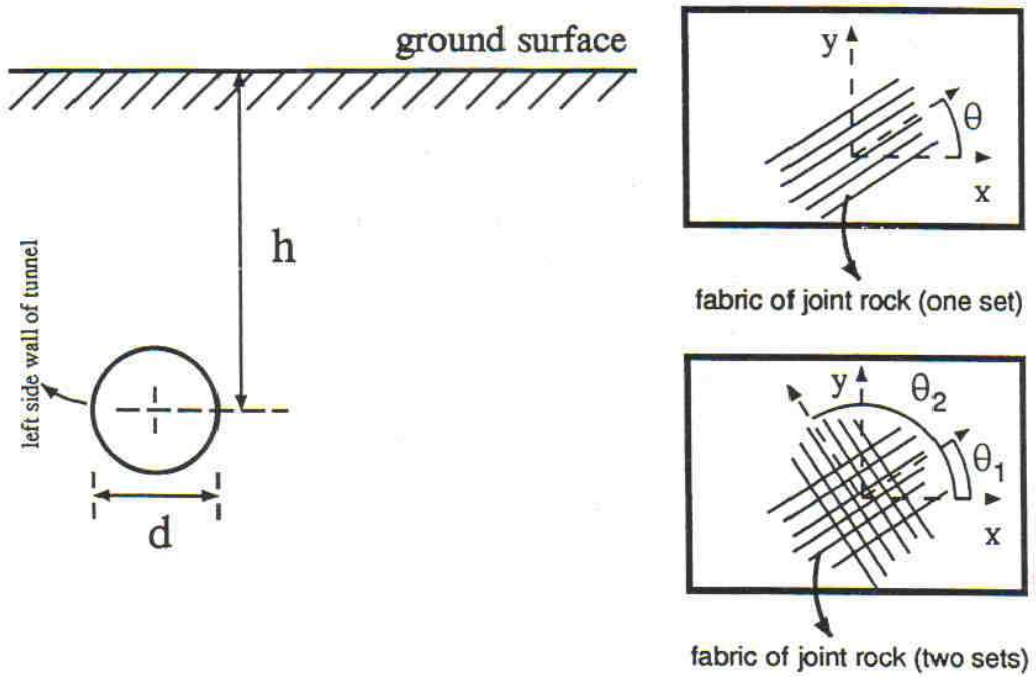

Figure 3 : Tunnel Geometry

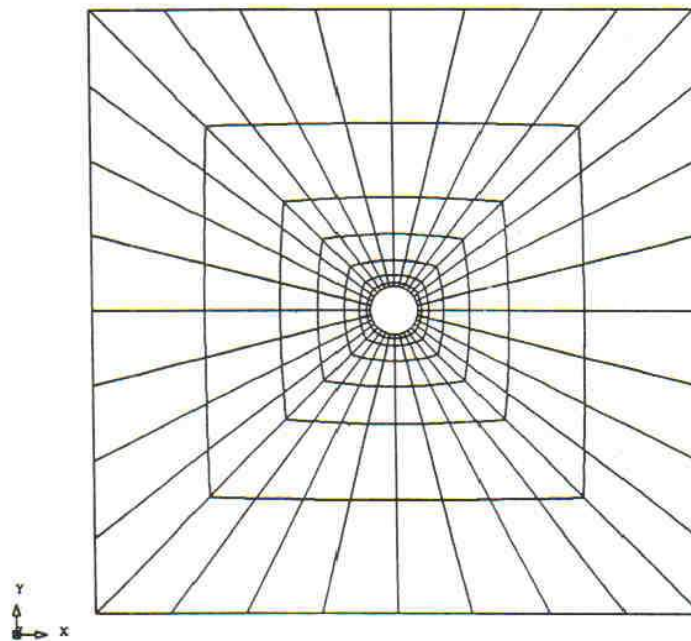
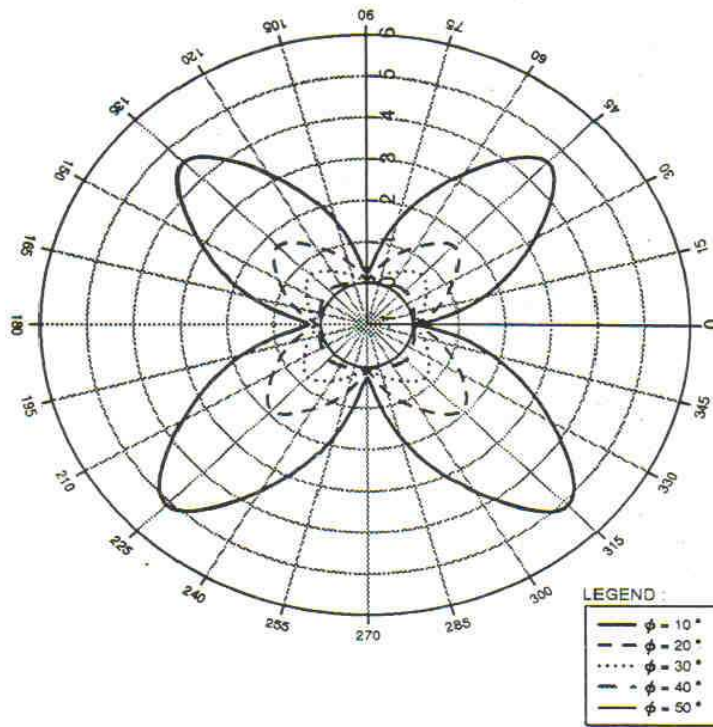
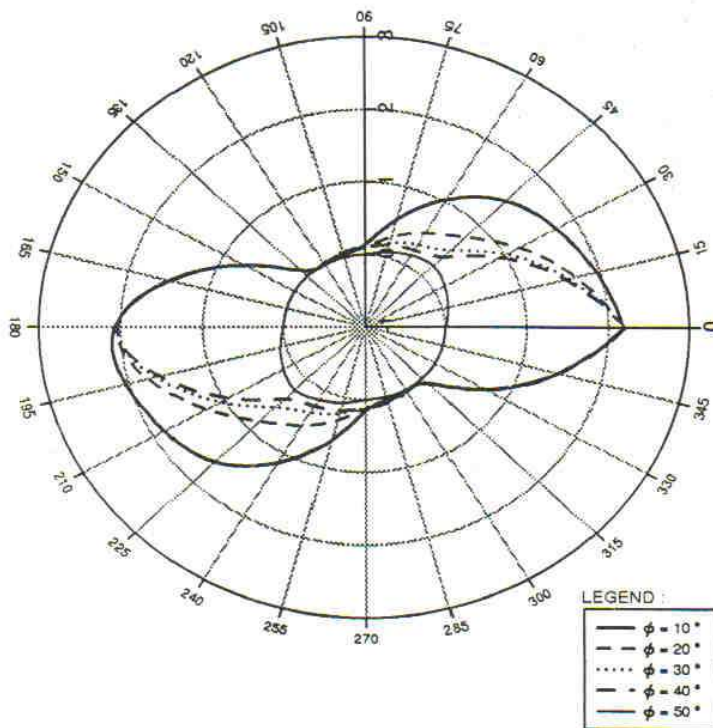

Figure 4 : Finite Element Mesh of Tunnel TYPE "sd0"



(a) joint orientation $\theta = 0^\circ$



(b) joint orientation $\theta = 45^\circ$

Figure 5 : Normalized Support pressure for "sd0" tunnels, for one set of joint, $K_o = 0.333$

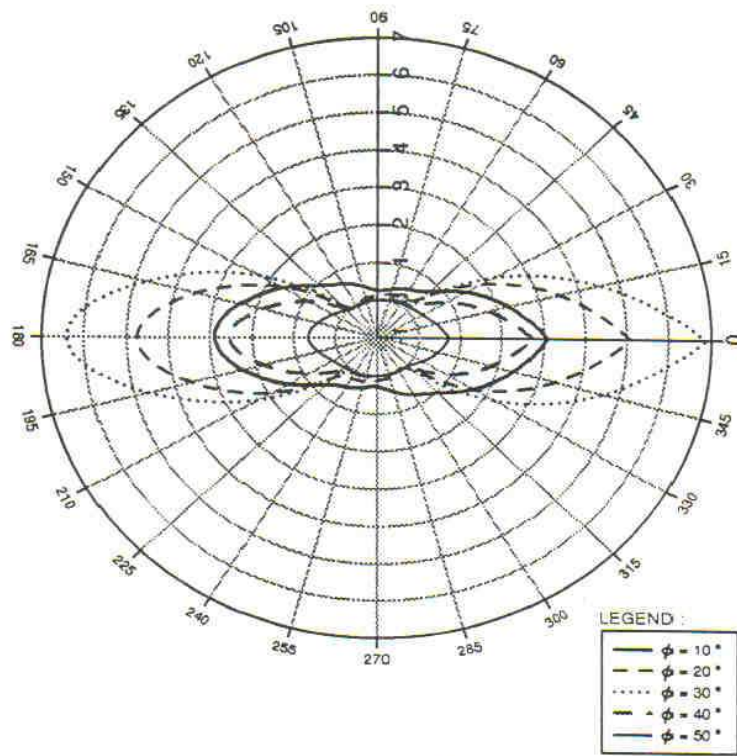

(c) joint orientation $\theta = 60^\circ$

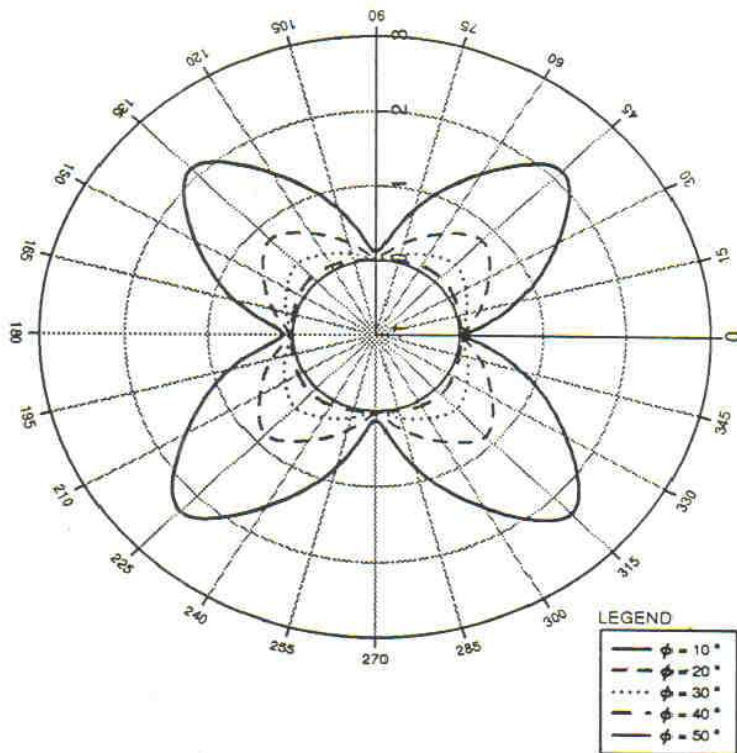

(d) joint orientation $\theta = 90^\circ$

Figure 5 : Normalized Support pressure for "sd0" tunnels, for one set of joint, 'Ko = 0.333

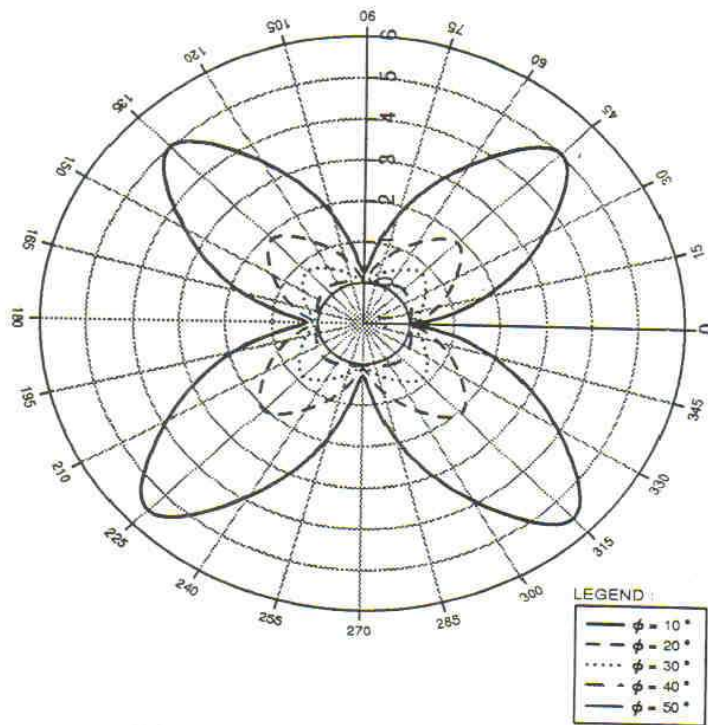

(a) joint orientation $\theta = 0^\circ$

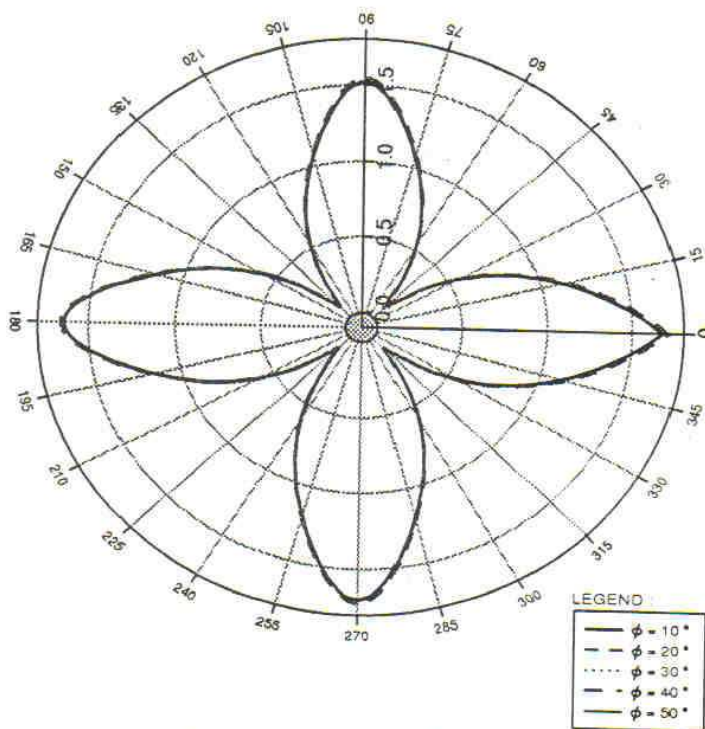

(b) joint orientation $\theta = 45^\circ$

Figure 6 : Normalized Support pressure for "sd0" tunnels, for one set of joint, $K_0 = 1.0$

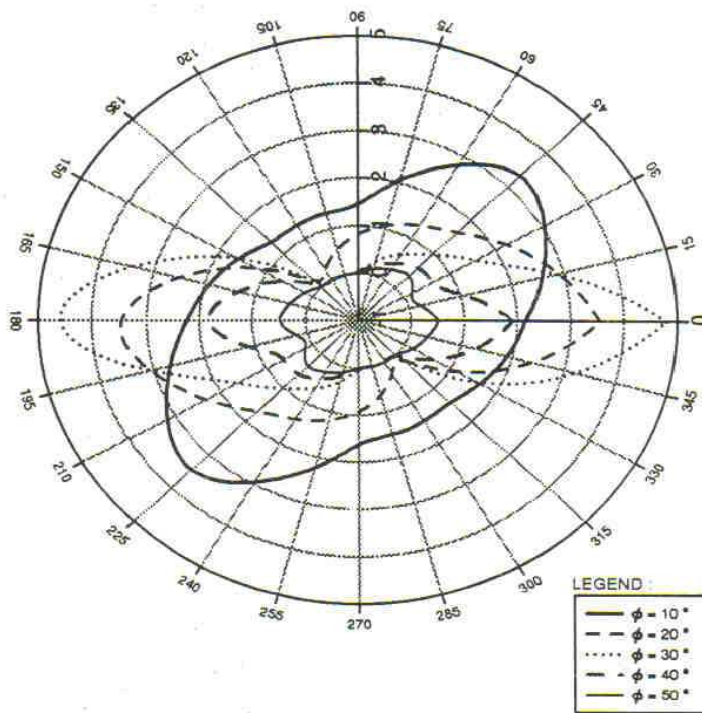

(c) joint orientation $\theta = 60^\circ$

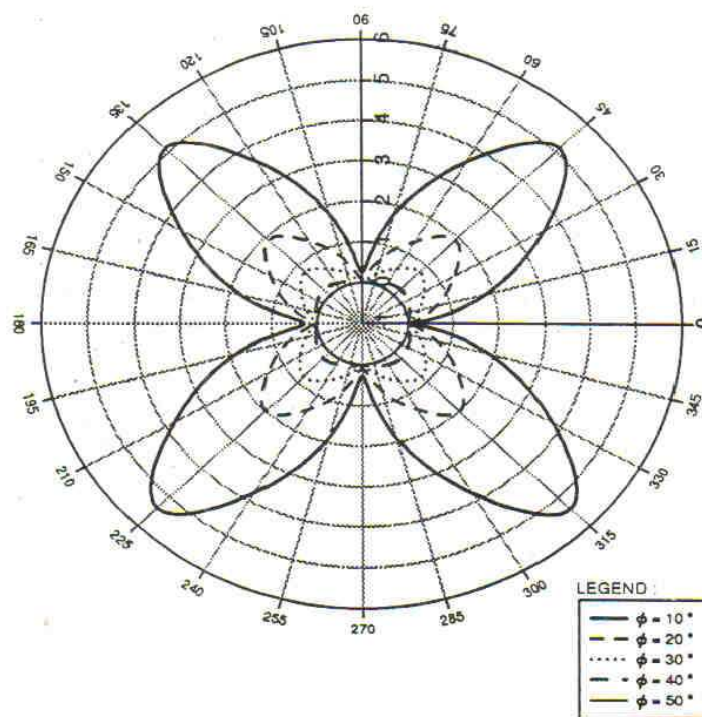

(d) joint orientation $\theta = 90^\circ$

Figure 6 : Normalized Support pressure for "sd0" tunnels, for one set of joint, $K_0 = 1.0$

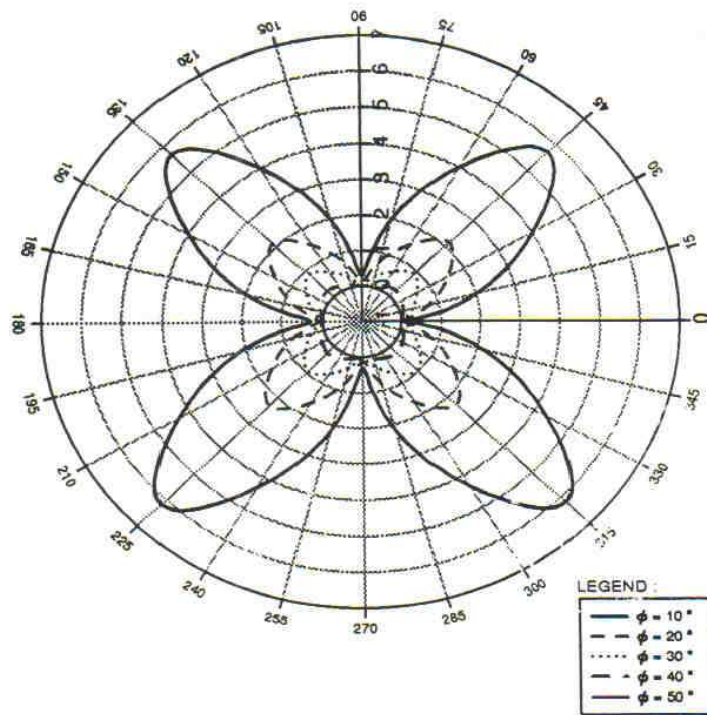

(a) joint orientation $\theta = 0^\circ$

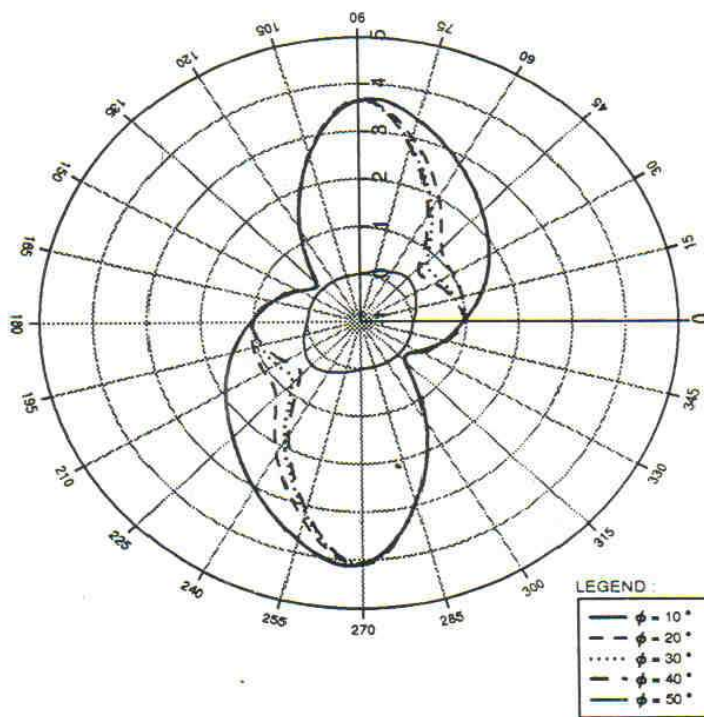

(b) joint orientation $\theta = 45^\circ$

Figure 7 : Normalized Support pressure for "sd0" tunnels, for one set of joint, $K_0 = 2.0$

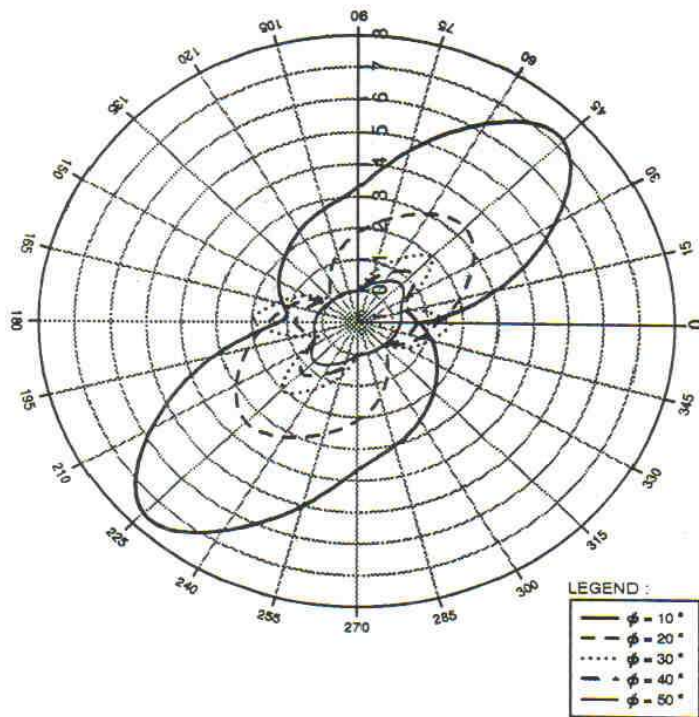

(c) joint orientation $\theta = 60^\circ$

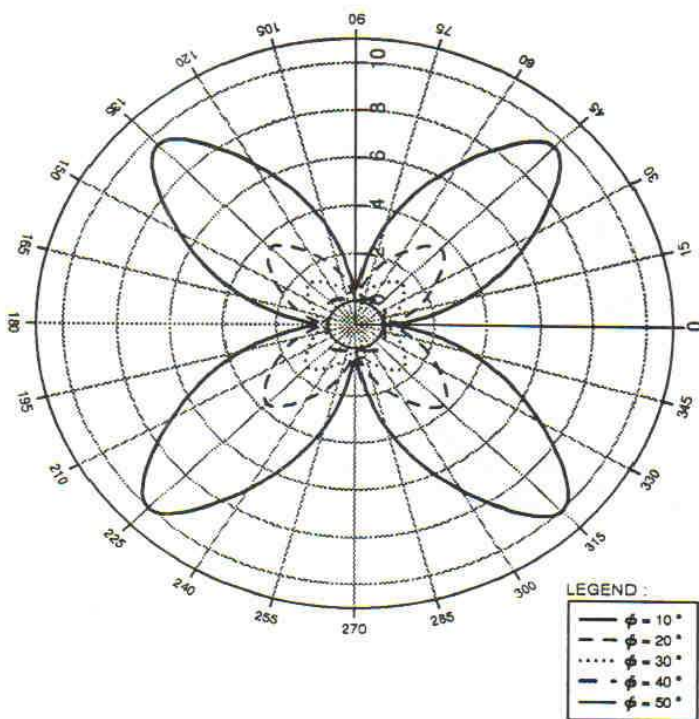

(d) joint orientation $\theta = 90^\circ$

Figure 7 : Normalized Support pressure for "sd0" tunnels, for one set of joint, $K_0 = 2.0$

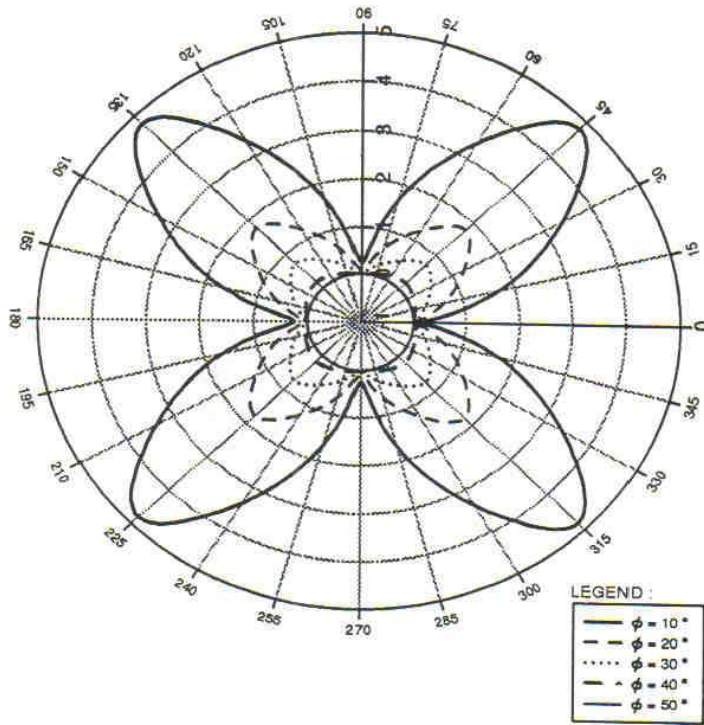

(a) joint orientation $\theta = 0^\circ$

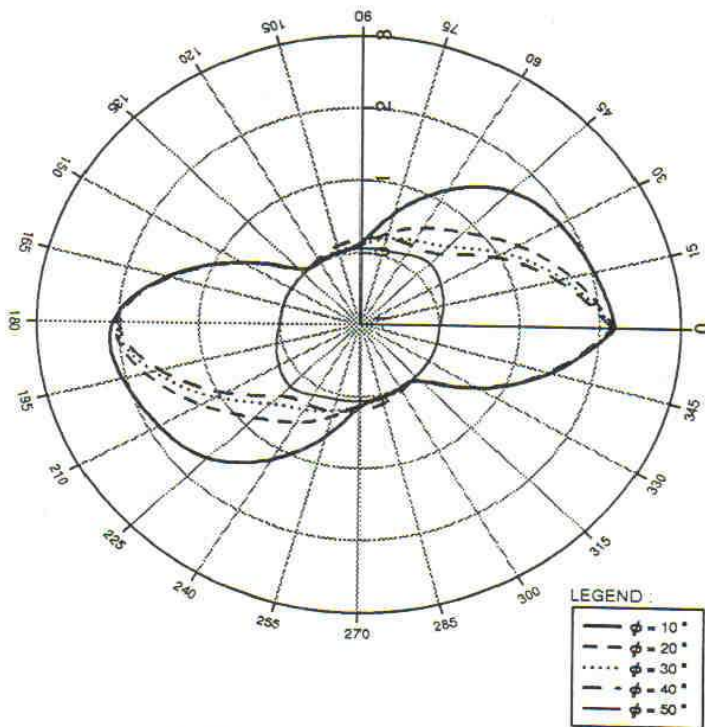

(b) joint orientation $\theta = 45^\circ$

8 : Normalized Support pressure for "vd4" tunnels, for one set of joint, $K_o = 0.333$

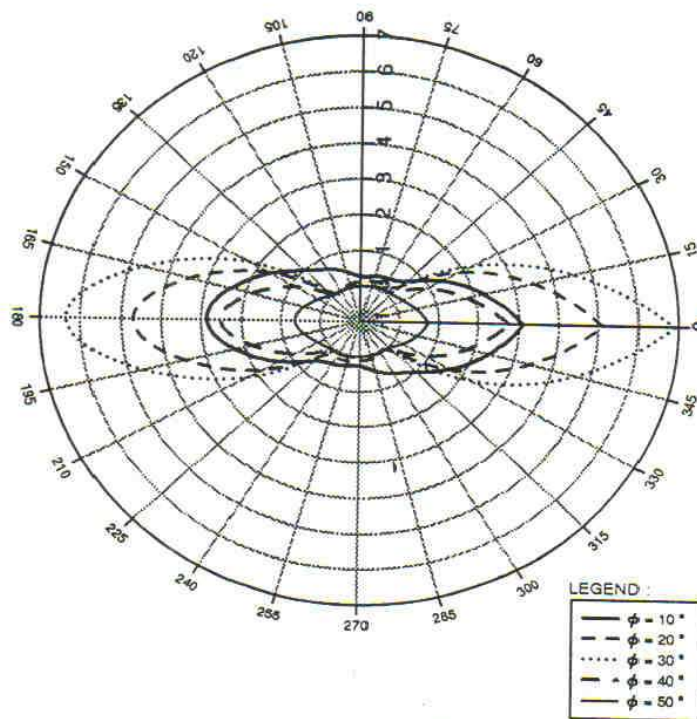

(c) joint orientation $\theta = 60^\circ$

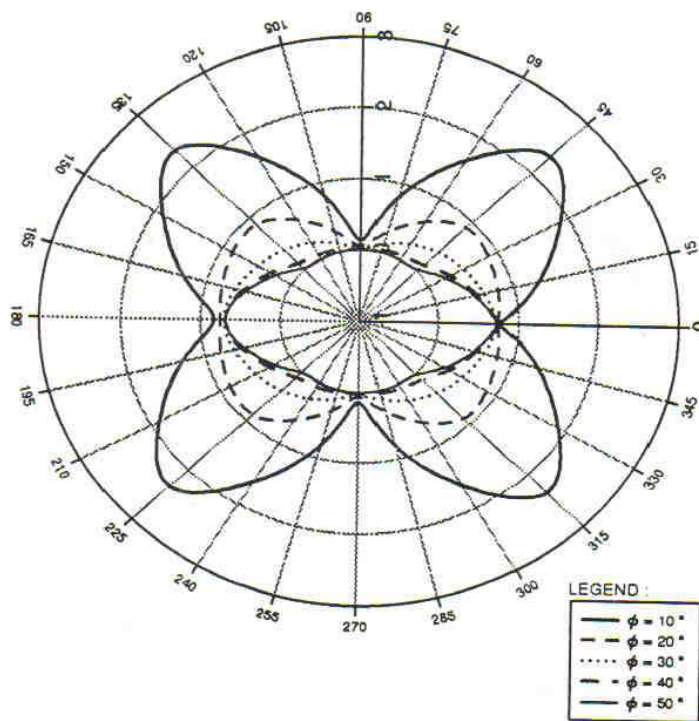

(d) joint orientation $\theta = 90^\circ$

Figure 8 : Normalized Support pressure for "vd4" tunnels, for one set of joint, $K_0 = 0.333$

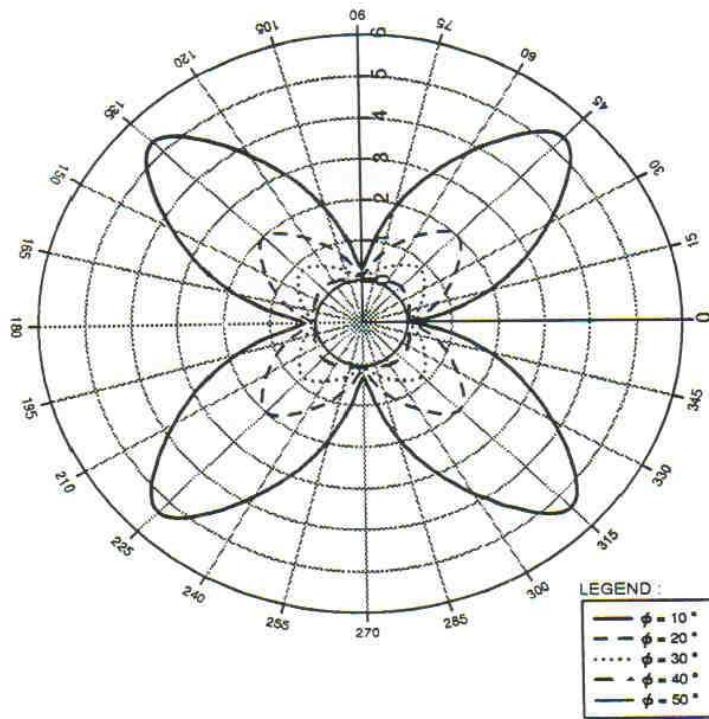

(a) joint orientation $\theta = 0^\circ$

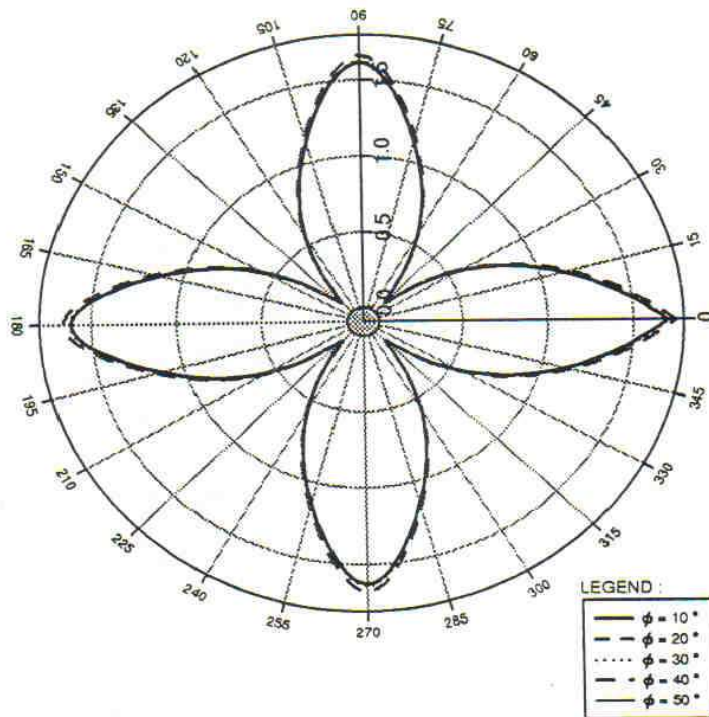

(b) joint orientation $\theta = 45^\circ$

Figure 9 : Normalized Support pressure for "vd4" tunnels, for one set of joint, $K_0 = 1.0$

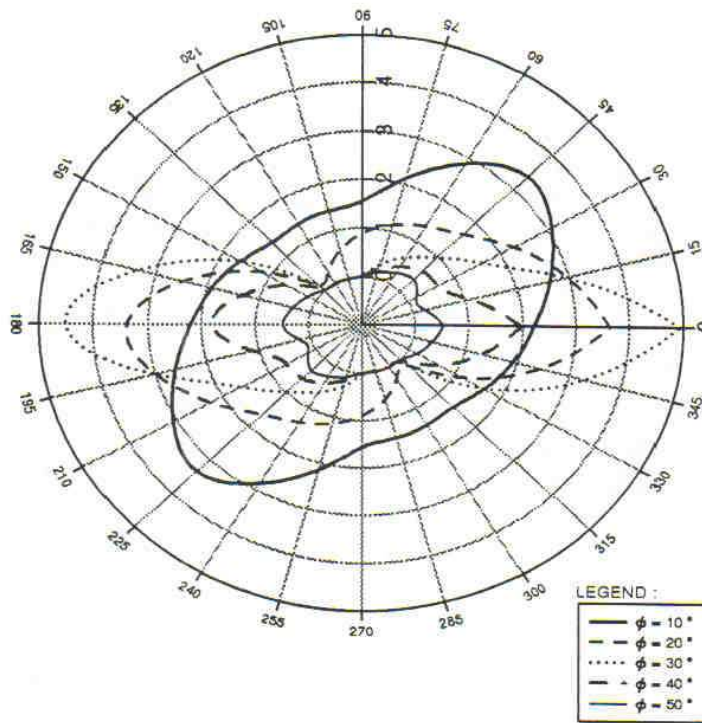

(c) joint orientation $\theta = 60^\circ$

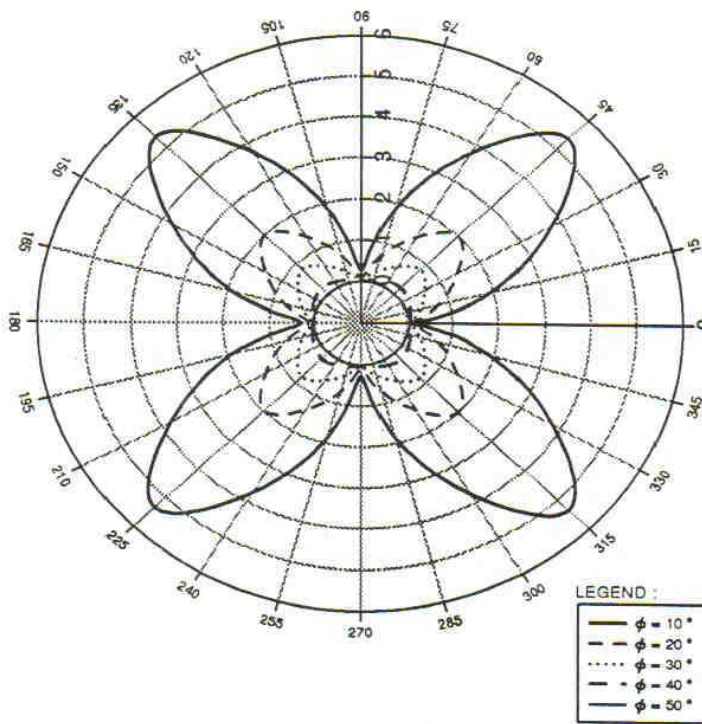

(d) joint orientation $\theta = 90^\circ$

Figure 9 : Normalized Support pressure for "vd4" tunnels, for one set of joint, $K_0 = 1.0$

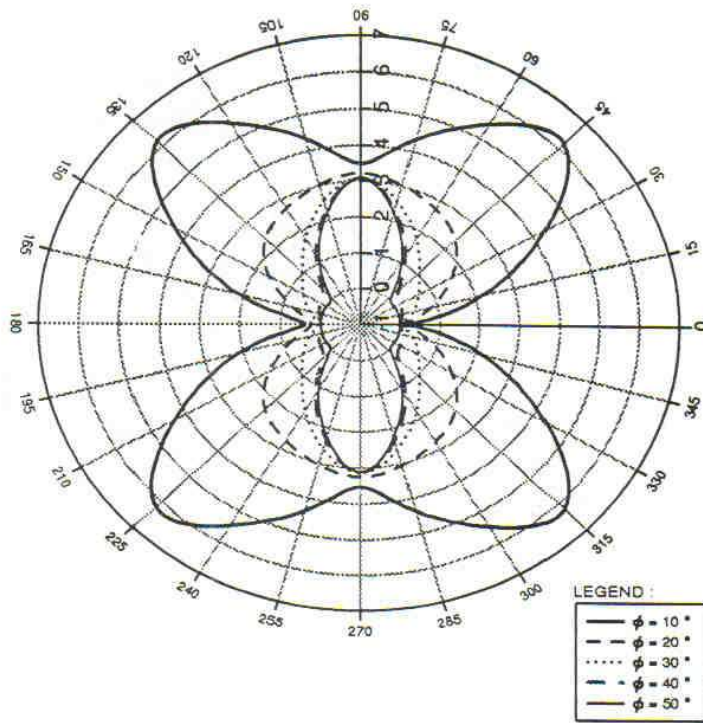

(a) joint orientation $\theta = 0^\circ$

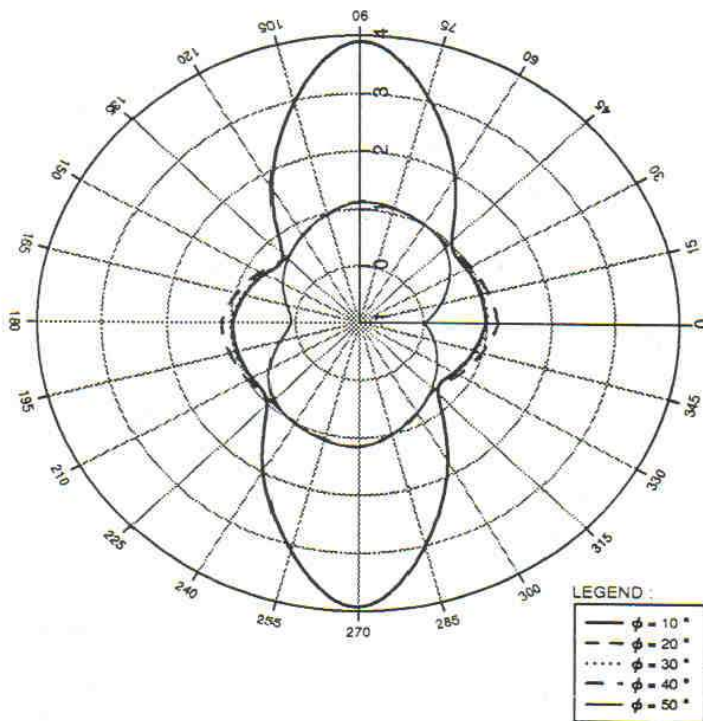

(b) joint orientation $\theta = 45^\circ$

Figure 10 : Normalized Support pressure for "vd4" tunnels, for one set of joint, $K_o = 2.0$

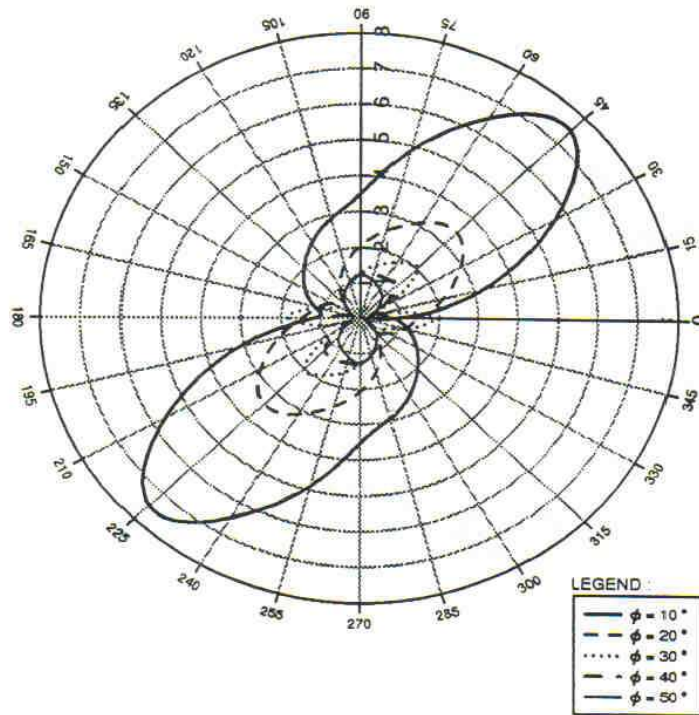

(c) joint orientation $\theta = 60^\circ$

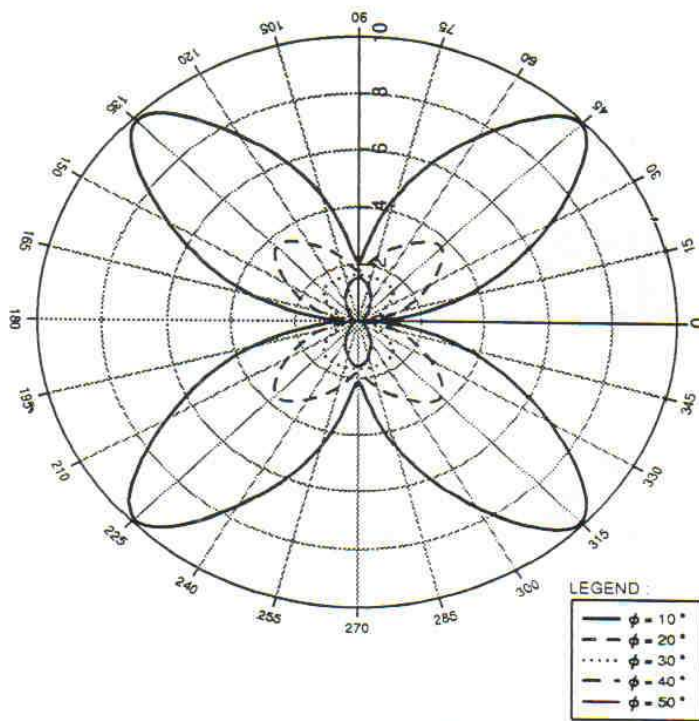

(d) joint orientation $\theta = 90^\circ$

Figure 10 : Normalized Support pressure for "vd4" tunnels, for one set of joint, $K_0 = 2.0$